

AC1049 Calibration Kit - Assembly Instructions

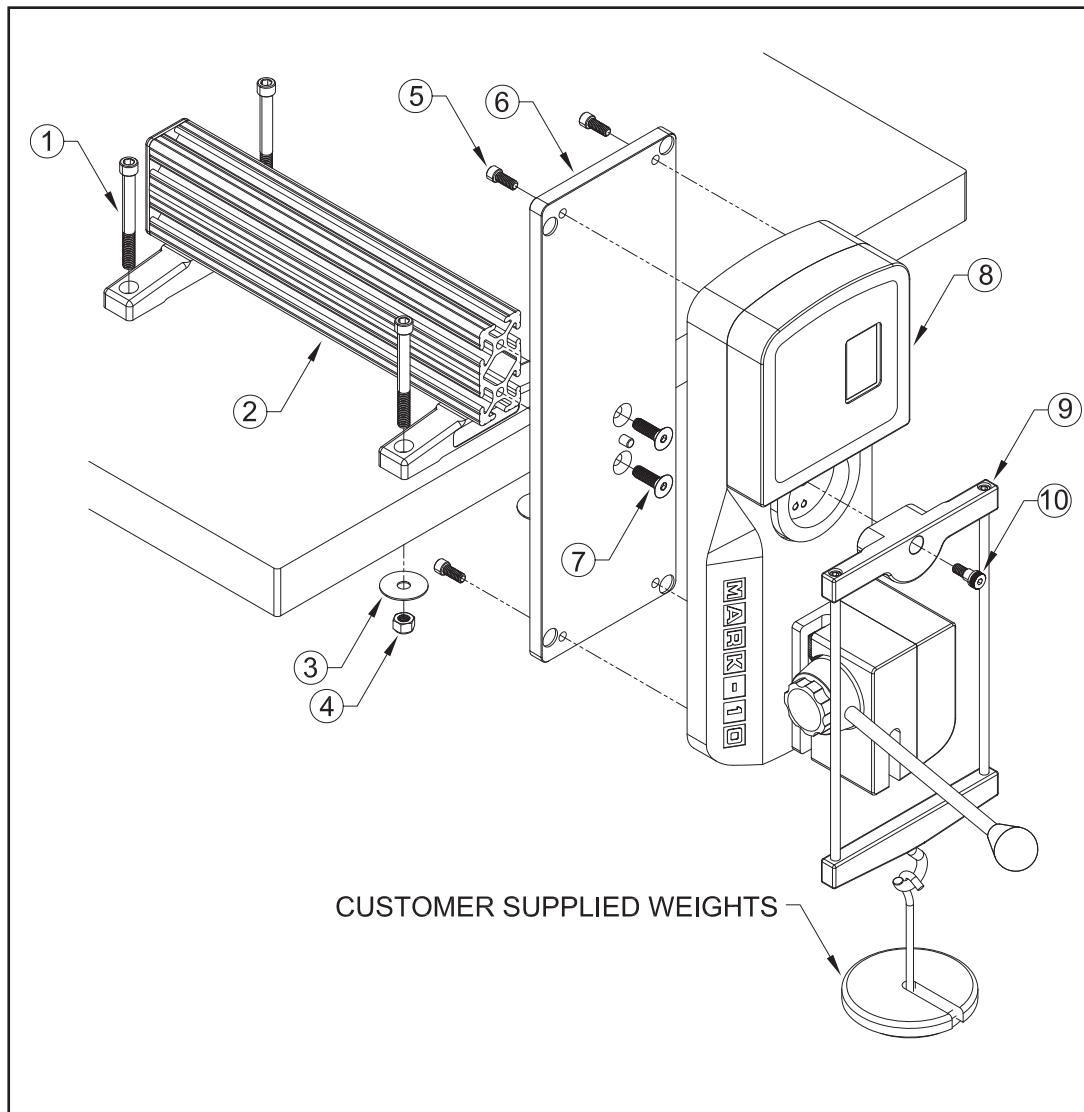

The AC1049 calibration kit is designed to permit field calibration of a WT3-200 wire terminal pull tester. The kit contains a complete set of attachments required to mount the tester to a bench and to accept weights (note: weights are not available from Mark-10).

The illustration at left depicts proper assembly. Please follow these instructions:

1. Orient the beam assembly (2) perpendicular to the edge of a bench. Ensure that the bench is sturdy enough to withstand a calibration weight of 200 lb suspended over its edge.
2. Drill four holes into the bench corresponding to the clearance holes in the two mounting feet.
3. Secure the feet to the bench utilizing the four socket head screws (1), washers (3), and nuts (4).
3. Secure the tester mounting plate (6) to the end of the beam utilizing two flat head screws (7).
4. Remove the wire terminal turret grip from the WT3-200 (8) by loosening the center socket head screw.
5. Mount the WT3-200 to the mounting plate (6) by matching the dowel pin to the blind hole, and fastening the four socket head screws (5).
6. Attach the calibration cage (9) to the tester, and tighten the socket head screw (10). The cage should be able to rotate freely.
7. Hang weights from the hook on the opposite end of the cage. It is recommended to calibrate the tester at five or more evenly spaced increments, such as 40, 80, 120, 160, and 200 lb. Refer to the WT3-200 user's guide for detailed calibration instructions.