

Series CTA

CAP TORQUE TESTERS

User's Guide

MARK-10®

Thank you!

Thank you for purchasing a Mark-10 Series CTA Cap Torque Tester. We are confident that you will get many years of service from this product.

The CTA can be used to test cap torque for a number of different closure shapes and sizes, along with other types of samples. To maintain normal functioning of the tester, avoid repetitive overloads and shock loads.

We hope that this User's Guide will provide a comprehensive explanation of the CTAs operation and sufficient detail on its specifications. However, if you have any other questions or concerns, our technical support and engineering teams will be eager to help you.

Thank you again for your purchase and happy testing!

TABLE OF CONTENTS

UNPACKING AND SETTING UP	3
LIST OF INCLUDED ITEMS.....	3
CONTROLS	4
DISPLAY	4
POWER.....	5
SETTING UP THE SAMPLE	5
CONFIGURATION.....	6
CALIBRATION	7
OUTPUTS	8
SPECIFICATIONS.....	9
DIMENSIONS	10
WARRANTY	10
OTHER MARK-10 PRODUCTS	11

UNPACKING AND SETTING UP

1. Carefully unpack the CTA and check for any damage. Inspect the contents to ensure that you have received a tester complete with all accessories – see “List of included items” below.
2. Place the tester on a firm, flat and level working surface free from vibration. If preferred, the CTA can be secured to a work bench with screws through the four tapped holes in the underside of the base. Then fasten the sample gripping posts into the desired holes on the sliders (see Fig. 1).

Quantity	Item
1	Series CTA Torque Tester
4	Sample gripping posts
2	Flat jaws set (optional, see below)
1	Adjustable jaws set (optional, see below)
1	Carrying case (optional)
1	AC adapter
1	Battery
1	Certificate of calibration

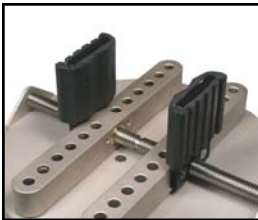

CT001 flat jaws (optional)

These jaws are designed for use with square or other shaped containers, in addition to round samples. The jaws are reversible; one side has a V-groove, while the other side is flat. These jaws can be mounted to the inside of the sliders, or the outside.



CT003 adjustable jaws (optional)

These jaws are designed for use with unique shaped samples. The four gripping arms per jaw may be independently repositioned in 45° increments to accommodate unique profiles. Loosen the screw at the top of the jaw to separate the arms and reposition as desired.

CONTROLS



POWER / ENTER

Turns power on and off. Also used to select configuration menu items.

PEAK / ADVANCE

Used to switch between Clockwise Peak, Counterclockwise Peak and Normal (real time) display modes. The actual peak readings are always captured and can be recalled at any time by pressing this button. Also used to step through configuration menu items.

ZERO

Zeros any tare value (up to the full capacity of the gauge) and clears the peak readings stored in memory.

DATA

Used to output the torque data point currently displayed.

UNITS

Changes measurement units between lbin, Ncm, and kgmm.

DISPLAY

The display consists of a 4 1/2-digit section and several indicators. Their functions are listed below.

LO BAT	Low battery voltage indicator
CW	Clockwise torque indicator
CCW	Counterclockwise torque indicator
CW PEAK	Peak clockwise torque indicator
CCW PEAK	Peak counterclockwise torque indicator
LBIN, NCM, KGMM	Units of measurement
---- (dashes)	Overload (>110% of range) Reduce torque immediately

POWER

The CTA can be operated by the included 9V non-rechargeable battery or by the included AC adapter. Battery life is approximately 30 hours.

Do not use adapters other than supplied or instrument damage may occur.

There are three levels of low battery voltage indication. At the first level the display shows a steady "LO BAT" indicating approximately one hour of charge remaining. The second level is indicated by a flashing "LO BAT" indicator. At the third level the whole display except the "LO BAT" indicator will flash for three seconds after which time the instrument will turn itself off. This prevents the instrument from working at voltages too low for reliable operation.

To access the battery, loosen the four screws on the bottom plate.

SETTING UP THE SAMPLE

Place the sample between the posts or jaws of the tester, and tighten, using the knob. Posts can be placed in any of the holes on the sliders (see Figs. 1 & 2 below). Ensure that the sample is gripped firmly, however, excessive tightening of thin-walled closures may result in sample deformation, possibly affecting test results. When the sample is secured, **gradually** exert torque by hand. Sudden torque application may produce incorrect readings.

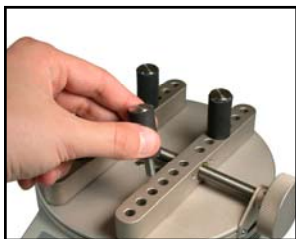

Fig. 1
Posts can easily be moved between holes

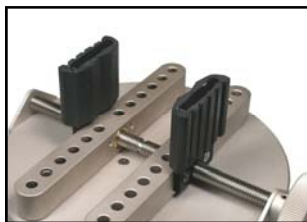

Fig. 2
Optional jaws offer alternative gripping methods

CONFIGURATION

Series CTA torque testers have several features with programmable options allowing many user-specified choices. To enter the configuration menu, perform the following:

1. Turn off the tester
2. Press and hold PEAK
3. Turn on the tester
4. Release PEAK

The version number of the internal software will be displayed for a short time. The following secondary functions of keys are used during the configuration process:

ENTER	Used to select a menu choice
ADVANCE	Used to step through menu choices

NOTE: Once the menu has been entered, it can only be exited if changes have been made.

The following list shows all configuration options. *Italics* indicate factory settings.

232 - RS-232 settings sub-menu

232d	Output Disabled
232E	Output Enabled
300	300 baud
600	600 baud
1200	1200 baud
2400	2400 baud
4800	4800 baud
9600	9600 baud
7-1E	7 data bits, 1 stop bit, even parity
7-1o	7 data bits, 1 stop bit, odd parity
7-2E	7 data bits, 2 stop bits, even parity
7-2o	7 data bits, 2 stop bits, odd parity
7-2n	7 data bits, 2 stop bits, no parity
8-1E	8 data bits, 1 stop bit, even parity
8-1o	8 data bits, 1 stop bit, odd parity
8-1n	8 data bits, 1 stop bit, no parity
8-2n	8 data bits, 2 stop bits, no parity
Ft F	Full data (numeric + units)
Ft n	Numeric data only

bcd - Mitutoyo BCD settings sub-menu

bcdd	Output disabled
bcd E	Mitutoyo BCD output enabled

AoFF - Automatic shutoff settings sub-menu

no	Disabled		
1	1-minute automatic shutoff		
5	5-minute	“	“
10	10-minute	“	“
20	20-minute	"	"
30	30-minute	"	"

init - Initial (default) settings sub-menu

LBIN	Pound-inch as default unit
KGMM	Kilogram-millimeter as default unit
NCM	Newton-centimeter as default unit
CCW	Real time display at turn on
PEAK CW	Peak clockwise display at turn on
PEAK CCW	Peak counterclockwise display at turn on

CAL - Calibration sub-menu. See CALIBRATION section.

CALIBRATION

To properly calibrate the CTA, application of a precise torque value equal to the full capacity of the tester in **pound-inches** (regardless of the displayed units) is required.

While holding PEAK, turn on power to the tester. When 'CAL' appears on the display, press ENTER three times to select the calibration mode. At the 'null' prompt, press ZERO. At the 'SPAN' prompt, apply the calibration torque and press ENTER. The display will show 'uuuu' or 'nnnn' if the calibration torque is insufficient or excessive, respectively. If this happens, the only way to terminate the calibration mode is by momentarily disconnecting the battery or connecting the AC adapter to the tester without plugging the other end into a wall outlet. This will stop the calibration procedure without making any changes to the previous calibration data.

Successful calibration is indicated by 'donE' on the display. Press ENTER to save the changes and resume normal operation.

OUTPUTS

RS-232

Data transmission can be initiated by pressing DATA or through an external device by sending ASCII "?". The tester will respond by sending the current reading in either full or numeric format, depending on the configuration setting (see Configuration section). Polarity sign indicates CW (+) or CCW (-) torque. The transmitted string has the following format:

[POLARITY (SPACE OR -)][DATA][SPACE][UNITS (IF ENABLED)][CRLF]

Mitutoyo BCD

This output is useful for connection to data collectors, printers, multiplexers or any other device capable of accepting Mitutoyo BCD data. The transmission is initiated by pressing DATA or by the receiving device.

I/O connector pin diagram

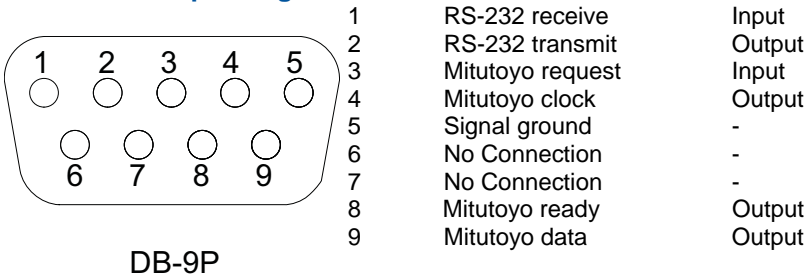

SPECIFICATIONS

Accuracy:	$\pm 0.5\%$ of full scale ± 1 digit
Sampling rate:	65/s
Display update rate:	2.5/s in normal mode, 65/s in peak mode
Safe overload:	150% of gauge capacity. Display shows ---- (dashes) above 110%.
Outputs (optional):	
RS-232:	Baud rates between 300 and 9600
Mitutoyo:	Standard Mitutoyo BCD output
Connector:	9-pin D-type male
Power:	9V battery or AC adapter
Battery life:	30 hours of continuous operation
Weight:	6.5 lb [2.9 kg]
Capacity x resolution:	
CTA12	12 x 0.01 lbFin, 140 x 0.1 kgFmm, 135 x 0.1 Ncm
CTA50	50 x 0.05 lbFin, 580 x 0.5 kgFmm, 570 x 0.5 Ncm
CTA100	100 x 0.1 lbFin, 1150 x 1 kgFmm, 1150 x 1 Ncm

DIMENSIONS

in [mm]

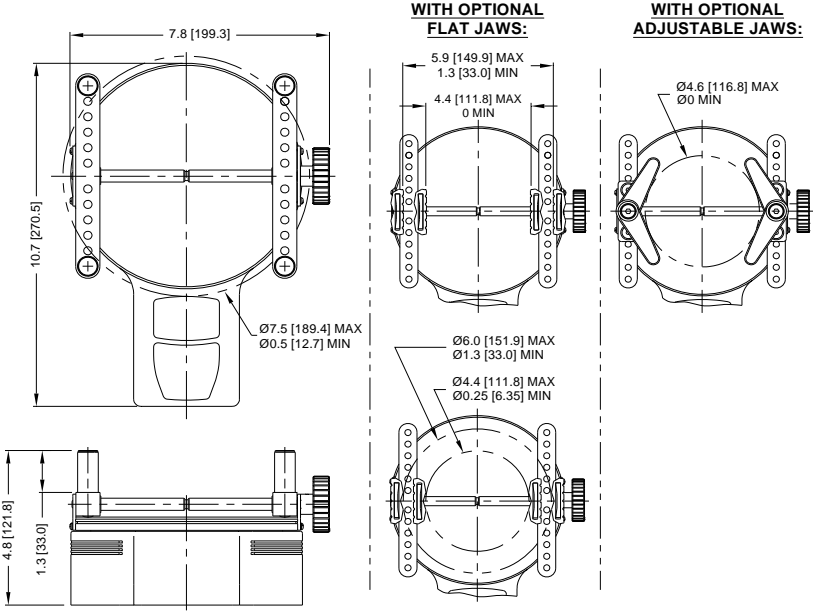

WARRANTY

Mark-10 Corporation expressly warrants to its buyer for three (3) years from the date of delivery that the goods sold are free from defects in workmanship and materials. Mark-10 Corporation will, at its option, repair or replace or refund the purchase price of goods found to be defective. This remedy shall be the buyer's sole and exclusive remedy. Any modification, abuse, exposure to corrosive environment or use other than intended will void this warranty. This warranty is in lieu of all other warranties, including implied warranties of merchantability and fitness for an intended purpose. In no event shall Mark-10 Corporation be liable for any incidental and consequential damages in connection with goods sold or any part thereof.

OTHER MARK-10 PRODUCTS

A full line of force and torque measurement products and related items, including force gauges, torque gauges, force and torque test stands, sensors, grips, software, and more.

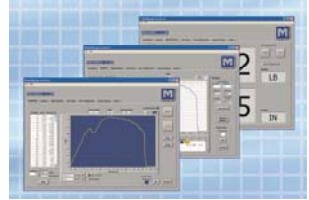



Mark-10 Corporation has been an innovator in the Force and Torque measurement fields since 1979. We strive to achieve 100% customer satisfaction through excellence in product design, manufacturing and customer support. In addition to our standard line of products we can provide modifications and custom designs for OEM applications. Our engineering team is eager to satisfy any special requirements. Please contact us for further information or suggestions for improvement.



We make a measurable difference in force and torque measurement

Mark-10 Corporation

11 Dixon Avenue
Copiague, NY 11726 USA
1-888-MARK-TEN
Tel: 631-842-9200
Fax: 631-842-9201
Internet: www.mark-10.com
Email: info@mark-10.com