

Controls

All Series MG torque gauges have three keys for controlling all functions of the instrument.

POWER	Turns the instrument on and off. Also used in the calibration mode.
PEAK	Used to select Clockwise Peak, Counterclockwise Peak or Normal (real time) display mode. The actual peak readings are always captured and can be displayed at any time.
ZERO	Zeros any tare value (up to the full capacity of the gauge) and clears the peak readings stored in memory.

Display

The display consists of a 4 1/2-digit section and several indicators. Their functions are listed below.

LO BAT	Low battery voltage indicator
CW	Clockwise torque indicator
CCW	Counterclockwise torque indicator
CW PEAK	Peak clockwise indicator
CCW PEAK	Peak counterclockwise indicator
OZIN, LBIN, NCM, KGMM	Units of measurement (Model dependent)
- - - - (dashes)	Overload (>110% of range)

Operation

The default mode of operation is the normal (real time) mode. If the peak readings are to be observed as they occur, then the mode of operation can be changed by pressing PEAK until the desired mode (CW PEAK or CCW PEAK) appears on the display. Please note that this action affects only the display. The peak readings are captured automatically and can be cleared from the memory by either pressing ZERO or shutting off the gauge.

The gauge is equipped with an automatic shutdown feature and it will shut off after approximately 30 minutes of inactivity (readings do not change by more than ± 10 counts and no keys are pressed). The entire display will flash for 5-7 seconds as a warning of the imminent shutdown. To change the default setting of 30 minutes, hold PEAK while turning on the gauge. Press PEAK repeatedly until 'AOFF' appears. Press POWER to select this function. The current setting will flash on the display. Use PEAK to scroll through the displayed choices and POWER to select. Press POWER again at the 'donE' prompt in order to save the setting.

The displayed units of measurement and the default mode of operation (peak or normal) can be changed by entering the setup mode as described above, pressing POWER at the 'init' prompt and selecting the desired settings using the PEAK and the POWER keys.

Power

The instrument may be powered by the internal 9V battery, or by the included AC adapter. The need for battery replacement is indicated by a 3-step sequence: 1 - a steady LO BAT appears on the display indicating the last 10% of the battery life, 2 - LO BAT begins to flash indicating the need for an immediate battery replacement, 3 - the entire display except LO BAT flashes for several seconds and then the instrument shuts off.

Calibration

To properly calibrate this instrument, application of a **precise torque value equal to the full capacity of the gauge in lbin or ozin (regardless of the displayed units)** will be required.

While holding PEAK, turn the gauge on. When 'CAL' appears on the display press POWER three times to select the calibration mode. At the 'null' prompt press ZERO. At the 'SPAN' prompt apply the calibration torque and press POWER. The display will show "uuuu" or "nnnn" if the calibration torque is insufficient or excessive accordingly. If this happens, the only way to terminate the calibration mode is by momentarily disconnecting the battery or connecting the AC adapter without plugging it into a wall outlet. This will stop the calibration procedure without making any changes to the previous calibration data. Successful calibration is indicated by 'donE' on the display. Press POWER to save the changes and resume normal operation.

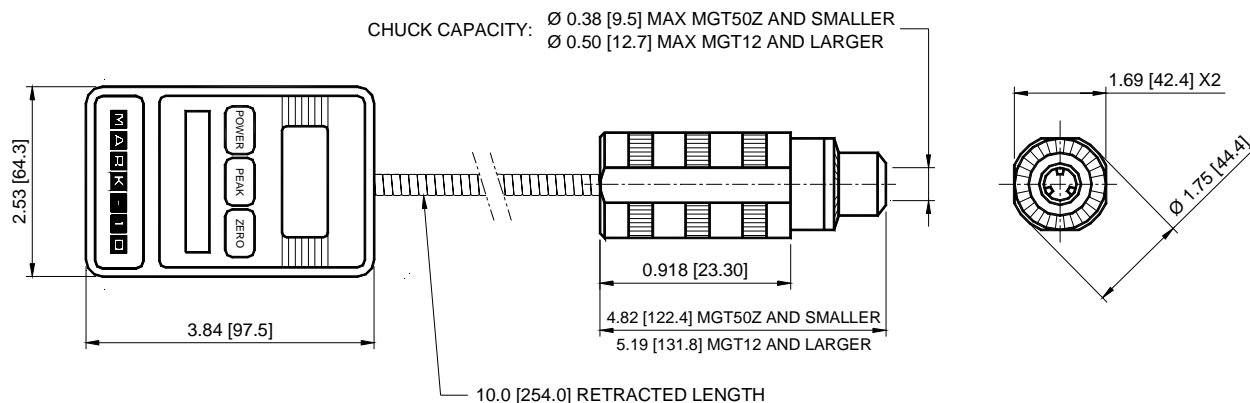

Model Capacity x graduation

MGT10Z	10.00 x 0.01 ozin, 7.000 x 0.005 kgmm, 7.000 x 0.005 Ncm
MGT20Z	20.00 x 0.02 ozin, 14.00 x 0.01kgmm, 14.00 x 0.01 Ncm
MGT50Z	50.00 x 0.05 ozin, 36.00 x 0.05 kgmm, 35.00 x 0.05 Ncm
MGT12	12.00 x 0.01 lbin, 140.0 x 0.1 kgmm, 135.0 x 0.1 Ncm
MGT50	50.00 x 0.05 lbin, 580.0 kgmm, 570.0 x 0.5 Ncm
MGT100	100.0 x 0.1 lbin, 1150 x 1 kgmm, 1150 x 1 Ncm

Specifications

ACCURACY	±0.5% of full scale ±1digit
SAMPLING RATE	30 readings/second
DISPLAY RATE	2.5/s in normal mode, 30/s in peak mode
SAFE OVERLOAD	150% of gauge capacity. Display shows ---- (dashes) above 110%
POWER	9V battery or AC adapter
BATTERY LIFE	30 hours of continuous operation
SIZE	See drawing
WEIGHT	1.8 lb [0.8 kg]



Mark-10 Corporation has been an innovator in the Force and Torque measurement fields since 1979. We strive to achieve 100% customer satisfaction through excellence in product design, manufacturing and customer support. In addition to our standard line of products we can provide modifications and custom designs for OEM applications. Our engineering team is eager to satisfy any special requirements. Please contact us for further information or suggestions for improvement.

User's Guide

Warranty

Mark-10 Corporation expressly warrants to its buyer for three (3) years from the date of delivery that the goods sold are free from defects in workmanship and materials. Mark-10 Corporation will, at its option, repair or replace or refund the purchased price of goods found to be defective. This remedy shall be the buyer's sole and exclusive remedy. Any modification, abuse, exposure to corrosive environment or use other than intended will void this warranty. This warranty is in lieu of all other warranties, including implied warranties of merchantability and fitness for an intended purpose. In no event shall Mark-10 Corporation be liable for any incidental and consequential damages in connection with goods sold or any part thereof.



We Make A Measurable Difference In Force & Torque Measurement

Mark-10 Corporation
11 Dixon Avenue
Copiague, NY 11726 USA
1-888-MARK-TEN
Tel: 631-842-9200
Fax: 631-842-9201
Internet: www.mark-10.com
E-mail: info@mark-10.com

