

These manually operated torque test stands are ideal for a wide variety of applications requiring up to 100 lbFin (11.3 Nm) of torque, including closure torque testing, fastener torque testing, and more. Smooth hand wheel operation ensures ease of use and a lever-operated slider with travel stops makes engaging and disengaging samples quick and efficient. The stand includes a torque loading plate with tapped holes for grip and custom fixture mounting and an angle dial indicator with 2° resolution and unlimited angular travel. Modular mechanical design allows the stand to be configured for a variety of applications.

Specifications

Torque capacity:	100 lbFin [11.3 Nm]
Maximum angular travel:	No limit
Angular rate:	12° per hand wheel revolution
Angle indicator resolution:	2°
Maximum slider travel:	15.5 in [394 mm] (column extensions available)
Slider travel rate:	1.047 in [26.6 mm] / lever revolution
Weight (without optional equipment):	TST: 33 lb [15 kg] / TSTH: 27 lb [12.3 kg]
Warranty:	3 years (see individual statement for further details)

>> Rotating torque plate includes a matrix of tapped holes for grip or fixture mounting

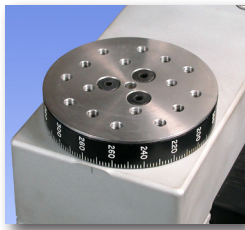

Optional Equipment

TST001 digital angle indicator	Displays CW or CCW angle with 0.1° resolution for approximately 278 rotations, resettable with zero button. Accurate to ±0.7°. Three sets of mounting holes allow the indicator to be mounted perpendicular to, or parallel to the test stand column. It can also be repositioned along the column.
Series R50 torque sensors	Series R50 sensors are recommended for use with Mark-10 torque test stands, available in 6 capacities from 10 ozFin to 100 lbFin (7 to 1,150 Ncm). Mount directly to the test stand.
Force/torque indicator	Displays reading from the torque sensor. Includes features such as data outputs, data averaging, set points, and more. Select from basic and advanced models.
Series TT03 torque gauge	Basic integrated torque gauge for various applications. Available in the same 6 capacities.

>> Digital angle indicator



The TST is shown with a Series R50 torque sensor and Model M5i force/torque indicator

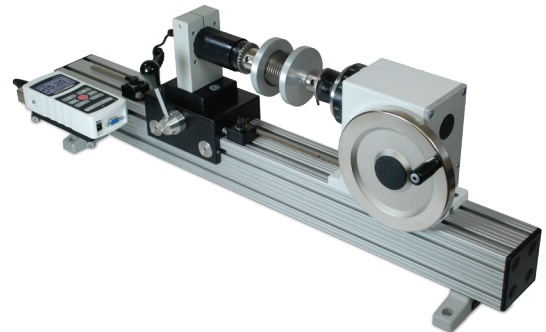

The TSTH is shown in a torsion spring test, with Series R50 torque sensor and Model M5i force/torque indicator

In The Box

The TST and TSTH test stands are shipped as shown at right, and include the following accessories:

- (1) Allen wrench set
- (1) Indicator mounting kit
- (1) Column cap with hardware
- (4) Thumb screw for mounting indicator
- (1) Base with hardware (TST)
- (2) Mounting leg with hardware (TSTH)
- (1) Additional column cap with hardware (TSTH)



Dimensions

TST

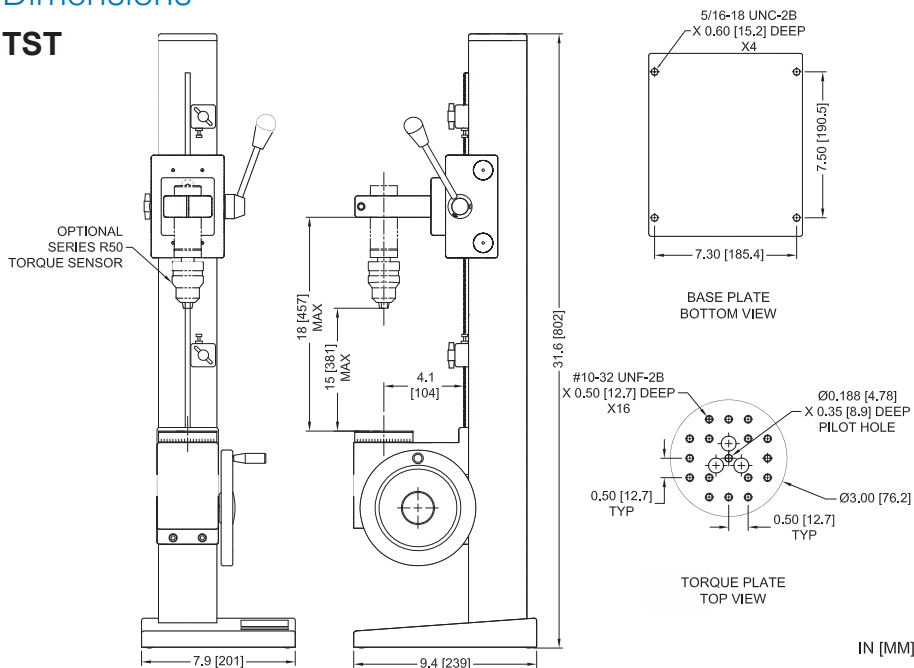

Dimensions

TSTH

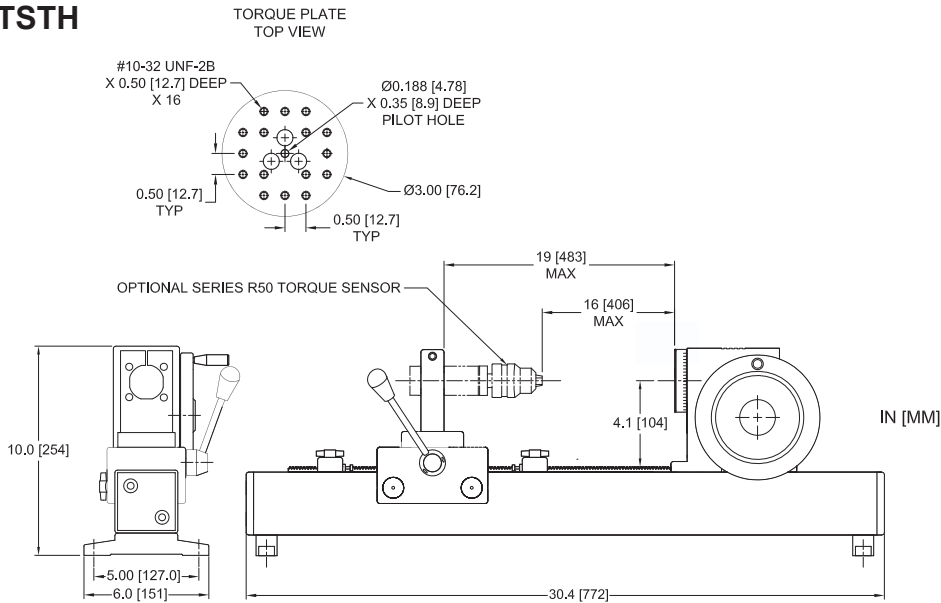

Ordering Information

Model No.	Description
TST	Torque test stand, vertical, lever-operated, 100 lbFin
TSTH	Torque test stand, horizontal, lever-operated, 100 lbFin
TST001	Digital angle display for TST/TSTH, 110V
TST001E	Digital angle display for TST/TSTH, 220V Euro