

Series **TSTM-DC**

Motorized Torque Test Stands

User's Guide

MARK-10[®]



Thank you...

Thank you for purchasing a Mark-10 Series TSTM-DC Torque Measurement Test Stand.

This user's guide is provided for the following models:

TSTM-DC
TSTMH-DC
TSTM-DC-1
TSTMH-DC-1
TSTM-DC-2
TSTMH-DC-2

With proper usage, we are confident that you will get many years of great service with this product. Mark-10 test stands are ruggedly built for many years of service in laboratory and industrial environments.

This User's Guide provides setup, safety, and operation instructions. Dimensions and specifications are also provided. For additional information or answers to your questions, please do not hesitate to

contact us. Our technical support and engineering teams are eager to assist you.

Note:

Except where otherwise indicated, references to "TSTM-DC" refers to all models within the series.

Before use, each person who is to use the test stand should be fully trained in appropriate operation and safety procedures.

TABLE OF CONTENTS

LIST OF INCLUDED ITEMS	3
SETUP AND SAFETY	3
OPERATION BASICS	7
TEST FUNCTION SETUP	9
OPERATING MODES.....	16
COMMUNICATION	19
MAINTENANCE AND SERVICE	21
TROUBLESHOOTING.....	21
SPECIFICATIONS	22
DIMENSIONS	23

1 LIST OF INCLUDED ITEMS



Qty.	Vertical models
1	Indicator mounting kit
4	Indicator mounting screws, #6-32 x 1/2
1	Series DC4040 control panel
1	Cable, control panel to test frame
1	Encoder cable
1	Base
1	Column cap with hardware
1	Allen wrench set
1	Power cord
	Horizontal models
1	Indicator mounting kit
4	Indicator mounting screws, #6-32 x 1/2
1	Series DC4040 control panel
1	Cable, control panel to test frame
1	Encoder cable
2	Mounting leg with hardware
2	Column cap with hardware
1	Allen wrench set
1	Power cord

Additional optional items are available, such as connection cables, and column extensions.

2 SETUP AND SAFETY

2.1 Unpacking and setting up

Carefully unpack the test stand from the box and inspect for any damage. Remove the foam from the middle portion of the test stand and remove the plywood caps by unscrewing the pair of screws at each end. Install the indicator mounting kit on the column. For the vertical models, install the base with four 5/16-18 x 1" screws and the top cap with four ribbed push-in rivets. For the horizontal models, install the two column caps with four ribbed push-in rivets per cap. Save all packaging materials for any future shipping.

2.2 Mounting

Place the stand on a clean, flat and level work area free from vibration.

For the vertical models, it is suggested to mount the stand to a work bench via screws fastened into the underside of the base. Failure to properly mount the test stand may make it more vulnerable to tipping, especially if a column extension is used, causing a hazardous situation.

If desired, the control panel can be secured to the work area with 1/4-20 screws fastened into the underside of the housing. The control panel can also be mounted using the ESM301-003 mounting kit. Screws of various lengths are supplied with this kit to accommodate a range of bench thicknesses. Refer to the following illustration for proper assembly:

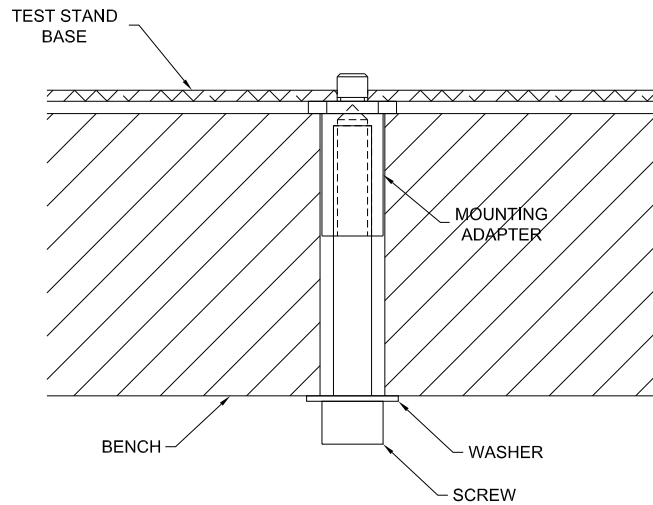

In general, the control panel can be mounted at any angle, although extra care should be taken during installation and operation.



IMPORTANT: Do not fasten any screws more than 0.25 in [6 mm] into the base of the control panel, or damage to internal components can occur.

2.3 Connections and outputs

The power plug and control panel cable must be connected to the rear of the control panel, as shown in the illustration below:

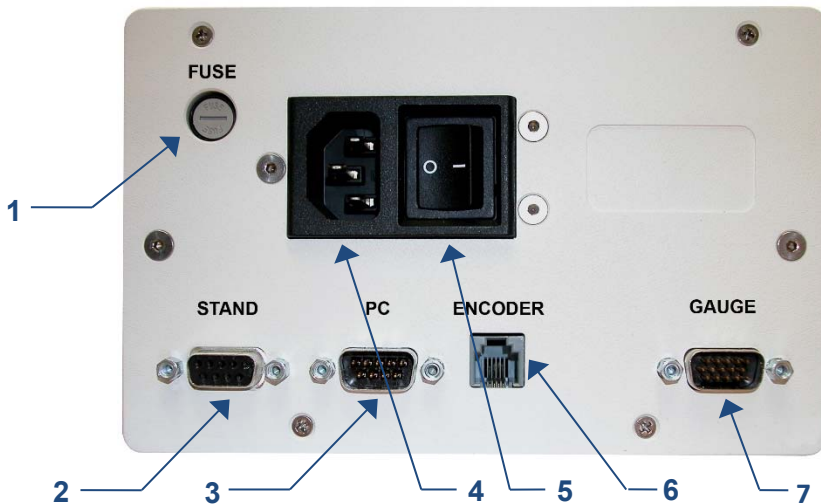

1. Fuse

2. Control Panel Cable Connector

Plug one end of the cable into this connector, and the other end into the connector as shown in the illustration on the right.

3. RS-232 Connector

Outputs torque only or torque and travel data via RS-232. Also allows for PC control, if appropriate functions are enabled. Plug one end of the 09-1056 serial cable into this connector, and the other end into a serial connector on a computer or USB converter.

4. Power Plug Receptacle

Plug the power cord in here. Refer to the **Connecting Power** sub-section for important safety information.

5. Power Switch

6. Angle Indication Connector

Plug one end of the RJ11 cable into this connector, and the other end into the connector in the bottom of the gearbox.

7. Indicator Cable Connector

Interfaces with an M7I or M5I. Plug one end of the 09-1162 cable into this connector, and the other end into the indicator.

2.4 Installing an Indicator with torque sensor

1. Once the test stand is in a stable and secure position, install an indicator via four thumb screws.
2. Install a torque sensor onto the slider bracket using the supplied hardware, and insert the Plug & Test connector into the indicator, as shown in the image below:



2.5 Installing the 09-1162 interface cable

If using test stand functions requiring communication between the torque sensor / indicator and test stand, such as data output, overload protection, etc., connect the interface cable between the instrument's connector and the indicator cable connector on the rear of the control panel. This cable may be used with an M5I or M7I indicator.

2.6 Safety / proper usage

Typical materials able to be tested include manufactured items such as springs, metals, plastics, electronic components, mechanical assemblies, packaging materials, and many others. Items that should not be tested include potentially flammable substances or products, items that can shatter in an unsafe manner, and any other components that can present an exceedingly hazardous situation when acted upon by torque.

When using a grip, ensure that it secures the sample in such a way that it is prevented from slipping out during a test, preventing a potential safety risk to the operator and others in the vicinity. If using a grip or fixture from a supplier other than Mark-10, ensure that it is constructed of suitably rugged materials and components.

2.7 Connecting power

Plug one end of the power cord into its receptacle at the rear of the control panel and the other end into a wall outlet with local earth ground (3-prong connector).

Before turning on power, the following safety checks and procedures should be performed:

1. Never operate the test stand if there is any visible damage to the power cord or the test stand itself. The test stand is powered by 110V/220V. Any contact with this high voltage can cause serious injury or even death.
2. Ensure that the test stand is kept away from water or any electrically conductive liquids at all times.
3. Make sure the electrical outlet powering the test stand has local earth ground (3-prong connector).

4. The test stand should be serviced by a trained technician only.

After the above safety checks and procedures have been performed, the test stand may be powered on and is ready for operation.

3 OPERATION BASICS

3.1 Operational safety

The following safety checks and procedures should be performed before and during operation:

1. Always consider the characteristics of the sample being tested before initiating a test. A risk assessment should be carried out beforehand to ensure that all safety measures have been addressed and implemented.
2. Wear eye and face protection when testing, especially when testing brittle samples that have the potential to shatter under torque. Be aware of the dangers posed by potential energy that can accumulate in the sample during testing. Extra bodily protection should be worn if a destructive failure of a test sample is possible.
3. Keep away from moving parts of the test stand. Loose articles of clothing should not be worn. Long hair should be covered to avoid a hazardous situation.
4. In those applications where samples can shatter, or other applications that could lead to a hazardous situation, use of a machine guard is strongly recommended.
5. When the test stand is not in use, ensure that the power is turned off to prevent accidental engagement of any of the controls.

3.2 Basic operation

The slider's position is adjustable along the column in order to engage and disengage the test sample. Move the slider lever clockwise to lower the slider's position closer to the torque plate. The slider may be locked into position by tightening the friction brake knob located on the opposite side of the slider.

The test stand may be operated by motor or by hand. To begin a motorized test, use the Control Unit to operate the test stand. For fine manual adjustment turn the knob on the motor drive in the desired direction.

3.3 Controls

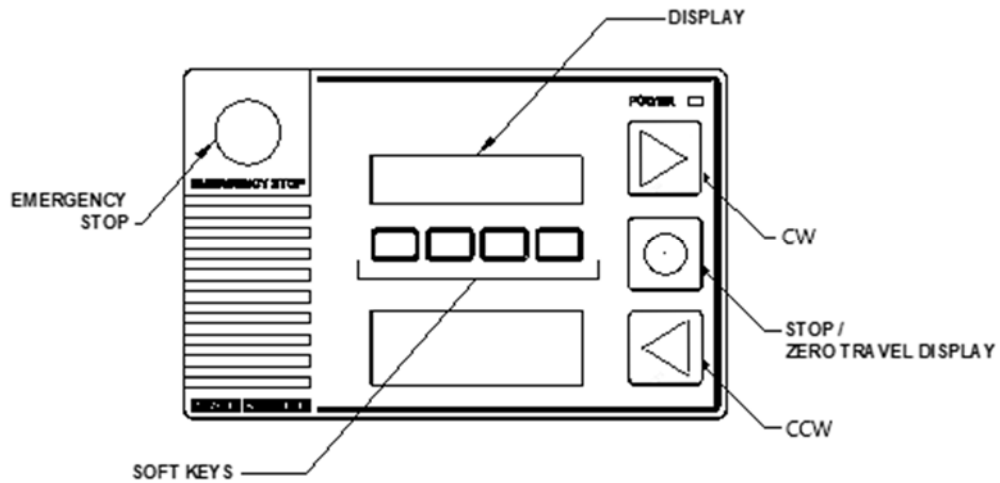

SOFT KEYS	Functions are determined by the corresponding text on the display.
CW	Initiates movement in the clockwise direction.
CCW	Initiates movement counterclockwise direction.
STOP	Stops movement.
EMERGENCY STOP	Stops movement and disables the test stand until reset.

3.4 Modes overview

The TSTM-DC has two functional modes:

1. **TEST FUNCTION SETUP**
In this mode, test functions are configured, such as rate of speed, number of cycles, password editing, and other functions.
2. **OPERATING MODE**
This is the operating mode in which testing sequences can be started and stopped.

4 TEST FUNCTION SETUP

This section provides configuration instructions for each function.

After pressing **menu**, the initial Test Function Setup screen appears as follows:

```
SPEED:      20.00
ESC  < - - >  ENTR
```

Label	Description
ESC	Exits Test Function Setup, reverts to Operating Mode
< -	Scrolls to the previous function
- >	Scrolls to the next function
ENTR	Selects the function, allowing it to be modified

When the parameters have been configured as desired and are ready to be saved, press **ESC** to exit Test Function Setup. The screen will show **SAVE CHANGES?** Pressing **YES** will save the changes and return to the Operating Mode. Pressing **NO** will not save the changes and return to Operating Mode.

Note: Changes can be made to an unlimited number of settings before saving.

4.1 Speed

Independent speeds can be set for both directions of movement.

Default setting: 10 RPM / 60°/s

Available settings:

TSTM-DC / TSTMH-DC: 0.01 - 15 RPM [0.05 - 90°/s]

TSTM-DC-2 / TSTMH-DC-2: 0.04 - 60 RPM [0.2 - 360°/s]

```
CW SPEED:   10.73
ESC  - +  ENTR
```

Label	Description
+	Increments the speed setting. Holding down + will increment at an increasingly faster rate.
-	Decrements the speed setting. Holding down - will decrement at an increasingly faster rate.
ENTR	Returns to the Test Function Setup menu
ESC	Exits the function without saving changes

4.2 Auto return

With this function, the torque plate moves to a limit (torque set point, angle/degree limit, or various event completions in the M7I), whichever occurs first, and stops. Then, the torque plate returns to the other limit and stops. The test speed is dictated by the setting described in the previous section. The return speed is locked to maximum speed.

Default setting: off

Available settings: off, on

```
AUTO RETURN  o f f
ESC    -    +    ENTR
```

Label	Description
+ or -	Cycles through the available settings
ENTR	Returns to the Test Function Setup menu
ESC	Exits the function without saving changes

Note:

If **AUTO RETURN** is turned **on**, **CYCLING** is automatically turned **off** and the **KEYS** function is automatically set to **MAINTAINED** mode. See following pages for details on the **CYCLING** and **KEYS** functions.

4.3 Cycling (CYCLES)

This setting allows the user to configure the number of CW and CCW cycles through which the torque plate will sequence. One cycle consists of the torque plate moving to a limit (torque set point, angle/degree limit, or various event completions in the M71.) whichever occurs first, at the specified speed, stopping for the specified amount of dwell time, and returning to the other limit at the specified speed.

Default setting: 00000 (off)

Available settings: 00000 – 99999

```
CYCLES :      0 0 0 0 0
ESC    -    +    ENTR
```

Label	Description
+	Increases the number of cycles in increments of 1. Holding down + will increment at an increasingly faster rate. If 99999 is reached the next number will be 00000 and continue incrementing.
-	Decreases the number of cycles in increments of 1. Holding down - will decrement at an increasingly faster rate. If 00000 is reached the next number will be 99999 and continue decrementing.
Press and hold + and - simultaneously	If pressed and held for 2 seconds or longer the number of cycles will change to 0.
ENTR	Returns to the Test Function Setup menu
ESC	Exits the function without saving changes

4.4 Dwell times (DWELL CW and DWELL CCW)

This setting corresponds to the amount of time, in seconds, for which the torque plate stops at the limit during a cycle sequence. Individually set dwell times can be applied to the CW and CCW limits.

Note:

The dwell time setting is unavailable for an auto return sequence.

Default setting: 0 (no dwell time)

Available settings: 0 – 9999.9

```
CW DWELL: 0000.0
ESC - + ENTR
```

Label	Description
+	Increases dwell time in increments of .1. Holding down + will increment at an increasingly faster rate. If 9999.9 is reached the next number will be 0 and continue incrementing.
-	Decreases dwell time in increments of .1. Holding down - will decrement at an increasingly faster rate. If 0 is reached the next number will be 9999.9 and continue decrementing.
ENTR	Returns to the Test Function Setup menu
ESC	Exits the function without saving changes

4.5 CW and CCW travel limits (CW L and CCW L)

This setting corresponds to the rotational travel distance the test stand moves before stopping or cycling. CW and CCW limits are programmed individually. The programmed distances are relative to the zero position of the test stand. The travel indicator can be zeroed by pressing and holding STOP for three seconds.

Default settings: 1 revolution

Available settings: ±2,777.77 revolutions

```
CW LM: 2.05
ESC - + ENTR
```

Label	Description
+	Increments the travel limit setting. Holding down + will increment at an increasingly fast rate.
-	Decrements the travel limit. Holding down - will increment at an increasingly fast rate.
ENTR	Returns to the Test Function Setup menu
ESC	Exits the function without saving changes

4.6 Overload analog output voltage (OVRLOAD V)

4.6.1 Function

The TSTM-DC protects a torque sensor from overload by measuring incoming analog voltage and stopping test stand travel when the programmed percentage of full scale has been reached. The default setting is for Mark-10 instruments ($\pm 1V$ full scale), however, the setting may be changed to $\pm 2V$ or $\pm 4V$ to accommodate other instruments.

Default setting: $\pm 1V$

Available settings: $\pm 1V$, $\pm 2V$, $\pm 4V$, OFF

```
OVERLOADV:  + / - 1
ESC      -  +  ENTR
```

Label	Description
+ or -	Cycles through the following available settings:
$\pm 1V$	$\pm 1V$ full scale
$\pm 2V$	$\pm 2V$ full scale
$\pm 4V$	$\pm 4V$ full scale
OFF	Overload protection is disabled
ENTR	Returns to the Test Function Setup menu
ESC	Exits the function without saving changes

4.6.2 CW and CCW overload settings (CW OVERLOAD and CCW OVERLOAD)

This setting corresponds to the percentage of full scale at which torque plate rotational travel stops. For example, a setting of 80% for a 100 lbFin capacity torque sensor would stop torque plate rotational travel when approximately 80 lbFin is reached.

Note:

Overload protection is active only for torque applied in the same direction of travel.

Default setting: 100%

Available settings: 20% - 100% (10% increments)

```
CW OVERLD: 100%
ESC      -  +  ENTR
```

Label	Description
+ or -	Increases or decreases the value.
ENTR	Returns to the Test Function Setup menu
ESC	Exits the function without saving changes

4.7 Control source (CONTROL)

This setting corresponds to the source of test stand control, as follows:

CONSOLE

The test stand is controlled from the control panel.

PC

The test stand is controlled from a custom-written application (not *MESURgauge Plus*). Refer to the **Communications** section for the complete serial command set. If any functions are changed

on the front panel, these settings will be ignored, except for **Auto Return** or **Cycling**. If either of these functions is turned on, PC control will be turned off.

Default setting: CONSOLE

Available settings: CONSOLE, PC

```
CONTROL : CONSOLE
ESC      -   +   ENTR
```

Label	Description
+ or -	Cycles through the available settings
ENTR	Returns to the Function Setup menu
ESC	Exits the function without saving changes

4.8 Baud rate

This setting corresponds to the baud rate setting of the computer program controlling the test stand.

Default setting: 19200

Available settings: 1200, 2400, 4800, 9600, 19200, 38400, 57600, 115200

```
BAUD RATE : 115200
ESC      -   +   ENTR
```

Label	Description
+ or -	Cycles through the available settings
ENTR	Returns to the Function Setup menu
ESC	Exits the function without saving changes

4.9 Stop bits and parity (STOP & PAR)

This corresponds to the stop bits and parity settings of the computer program controlling the stand.

Default setting: 8-1n

Available settings:

- 8-1E 8 stop bits, 1 stop bit, even parity*
- 8-1o 8 stop bits, 1 stop bit, odd parity*
- 8-1n 8 data bits, 1 stop bit, no parity*
- 8-2n 8 data bits, 2 stop bits, no parity*
- 7-1E 7 data bits, 1 stop bit, even parity*
- 7-1o 7 data bits, 1 stop bit, odd parity*
- 7-2E 7 data bits, 2 stop bits, even parity*
- 7-2o 7 data bits, 2 stop bits, odd parity*
- 7-2n 7 data bits, 2 stop bits, no parity*

```
STOP & PAR : 8 - 1 n
ESC      -   +   ENTR
```

Label	Description
+ or –	Increases or decreases the value
ENTR	Returns to the Test Function Setup menu
ESC	Exits the function without saving changes

4.10 Units of speed (UNITS)

This setting corresponds to units of speed and travel measurement.

Default setting: RPM

Available settings: RPM, %/sec

UNITS :	RPM
ESC	- + ENTR

Label	Description
+ or –	Cycles through the available settings
ENTR	Returns to the Test Function Setup menu
ESC	Exits the function without saving changes

4.11 Programmable button function (KEYS)

Three button function modes are available:

1. Maintained

The torque plate will rotate continuously once the button has been pressed and held. Subsequently pressing **STOP** will stop torque plate motion.

2. Momentary

The torque plate will rotate only if the button is held down. Releasing the button will stop movement immediately.

3. Auto

Holding down the button for more than 0.5 second will enter momentary mode, at which time an audible indicator will sound and the LED indicator on the button pushed will be illuminated. A short tap on the button will operate the test stand in maintained mode. Pressing **STOP** during maintained mode will stop torque plate rotation.

Default setting: maintained

Available settings: maintained, momentary, auto

KEYS :	MAINTAINED
ESC	- + ENTR

Label	Description
+ or –	Cycles through the available settings
ENTR	Returns to the Test Function Setup menu
ESC	Exits the function without saving changes

4.12 Default settings

Revert to factory settings, as follows:

CW SPEED:	10 RPM
CCW SPEED:	10 RPM
AUTO RETURN:	off
CYCLING:	00000 (off)
CW LM:	1.00 revolution
CCW LM:	-1.00 revolution
OVERLOAD V:	+/- 1
CW OVERLOAD:	100%
CCW OVERLOAD:	100%
CONTROL:	CONSOLE
BAUD RATE:	19200
STOP BITS & PARITY:	8-1n
UNIT:	RPM
KEYS:	maintained
PASSWORD:	0000 (off)

DEFAULT ? :	NO
ESC - + ENTR	

Label	Description
+ or -	Cycles through “yes” or “no” selections
ENTR	Returns to the Test Function Setup menu
ESC	Exits the function without saving changes

4.13 Password (NEW PWORD)

If desired, a password can be set to prevent unwanted changes to test functions. The password can be set to any number between 0000 and 9999. The default setting of 0000 indicates that the password is disabled, and that the user can freely enter the Test Function Setup menu.

Default setting: 0000 (off)

Available settings: 0000 – 9999

NEW PWORD	0 0 0 0
ESC - + ENTR	

Label	Description
+ or -	Increases or decreases the value.
ENTR	Returns to the Test Function Setup menu
ESC	Exits the function without saving changes

If the password is misplaced or forgotten, an *activation code* is required. While in Operating Mode, press and hold **STOP**, then press **menu** simultaneously, and release both buttons. Scroll to the right until “DISABLE PASSWORD” is displayed. Press ENTR to generate a *request code*, then provide it to Mark-10, who will supply a corresponding *activation code*. The process for entering the *activation code* is as follows:

1. The first digit of the *request code* will be flashing. Press **+** to increment the digit. Pressing **+** when the number 9 is displayed will cycle to 0.

2. Press → to advance to subsequent digits, and change them in the same manner.
3. Press **ENTR** when complete. If an incorrect code is entered, the display will revert to the password reset menu. If this happens the above process must be repeated.

5 OPERATING MODES

5.1 Overview

The TSTM-DC can be operated in several modes, including combinations of these modes:

1. **Basic Mode**
Manual control of test stand movement.
2. **Auto Return Mode**
Test stand moves to a limit switch, torque set point, or rotational travel distance, whichever occurs first, then reverses and moves at maximum speed to the other limit, whichever occurs first.
3. **Cycling Mode**
Test stand cycles between limits at the selected speed, and pauses at each limit for a selected period of time.
4. **PC Mode**
Test stand is controlled through a serial connection with a computer.

The Operating Mode screen appears as follows:

POSITION	SPEED
↓	↓
1 . 2 7	0 . 0 0
m e n u m i n m a x S E T	

The item selected will be capitalized, as shown in the figure above. The **set** speed can be changed in Test Function Setup. Independent speeds may be programmed for each direction.

5.2 Menu navigation

At power-up, the display will show the operation screen for whichever mode was used last. The display will appear as one of the following:

1. Basic & Auto Return Modes:

POSITION	SPEED
↓	↓
1 . 2 7	0 . 0 0
m e n u m i n m a x S E T	

2. Cycling Mode:

```

1 . 27      0 0 0 2 4
menu min max SET
  
```

3. PC Control Mode

Appears the same as in Basic and Auto Return modes.

Label	Description
menu	Enters Test Function Setup
min	Sets speed to minimum speed. Will not appear when a password has been set.
max	Sets speed to maximum speed. Will not appear when a password has been set.
set	Sets speed to the programmed value.

Pressing **menu** will enter Test Function Setup. If a password has been programmed, the display will prompt the following:

```

PASSWORD      0 0 0 0
ESC  -  +  ENTR
  
```

The password is a four-digit number. Press **+** or **-** to increment or decrement the number. Once the complete password has been entered, press **ENTR**. If correct, the display will enter the Test Function Setup menu. If the password is incorrect, the display flashes "INCORRECT PASSWORD", and then reverts to Operating Mode.

5.3 Basic mode

The test stand rotates clockwise when **CW** is pressed, and counter clockwise when **CCW** is pressed. When the test stand is in motion, an LED indicator on the button pushed will be illuminated. The **KEYS** setting controls how test stand movement responds to the push of either of the directional buttons. The three settings are:

- Maintained (default)**
 The torque plate will rotate continuously once the button has been pressed. Subsequently pressing **STOP** will stop test stand motion.
- Momentary**
 The torque plate will rotate only if the button is pressed and held. Releasing the button will stop rotation immediately.
- Auto**
 Holding down the button for more than 0.5 seconds will enter **Momentary** mode, at which time an audible indicator will sound and the LED indicator on the button pushed will be illuminated. A short tap on the button will operate the test stand in **Maintained** mode. Pressing **STOP** during **Maintained** mode will stop rotation. To resume the test, press **CW** or **CCW** again.

Pressing **EMERGENCY STOP** will immediately stop rotation in any mode. To release, twist the button clockwise until it assumes its original position. To resume the test, press either directional button for two seconds.

The torque plate will rotate until a limit has been reached. If the test stand has stopped at a soft limit, the limit condition may be overridden by pressing and holding either directional button for two seconds.

5.3.1 Travel indication

The position is displayed in the upper left corner of the display. The unit of measurement is dictated by the **UNITS** function. To zero the value, press and hold the **STOP** key. The position will not be retained during power cycles.

5.3.2 Overload protection

The available interface cable is required for overload protection of a Mark-10 torque sensor. If overload protection is enabled, the test stand will stop when the programmed percentage of full scale of the instrument has been reached.

When overload protection is enabled, if the cable is disconnected, and/or if the instrument is powered off, an error message will appear. Plug in the cable and/or turn on the instrument to clear the message.

Note:

When the torque plate is rotating in the clockwise direction, only the clockwise overload setting is active. When rotating in the counter-clockwise direction, only the counter-clockwise overload setting is active.

5.4 Auto return mode

In this mode the torque plate rotates at the set speed to whichever limit it encounters first and stops. Then, it returns at maximum speed to the opposite limit, whichever occurs first, and stops. Press either directional button to initiate an Auto Return sequence.

The test stand can be stopped at any time during an Auto Return sequence by pressing **STOP**. To resume the test, press either directional button.

Note:

If the test stand has stopped at a soft limit, the limit condition may be overridden by pressing and holding either directional button for two seconds.

5.5 Cycling mode

This mode cycles the torque plate between limits, whichever occurs first. One cycle consists of the following steps:

1. Torque plate rotates to a limit at the specified speed.
2. Torque plate stops for the specified amount of dwell time.
3. Torque plate reverses direction, returns to the other limit at the specified speed, and stops for the specified amount of dwell time.

A cycling sequence can be initiated from any position and can start in either direction. To initiate a cycle sequence, press either directional button. During a cycle sequence, a counter will be displayed, indicating the number of cycles remaining, as shown below:

1 . 27	0 0 0 2 4
menu min	max SET

As in Basic Mode, the **min**, **max**, and **set** soft keys are active during test stand movement.

When the cycling sequence and the test stand has stopped at a *soft limit*, the limit condition may be overridden by pressing and holding either directional button.

5.5.1 Dwell time

Dwell time is the amount of time, in seconds, for which the torque plate stops at a limit during a cycle sequence. When the limit is reached, a counter will be displayed, shown as follows:

1 . 2 7	0 0 0 1 . 5
menu min max	SET

If the dwell settings are set to 0, the torque plate will immediately reverse direction upon reaching the corresponding limit, and no counter will be displayed.

The cycle sequence may be interrupted before it has been completed by pressing **STOP**. A soft key labeled **RESET** will appear as follows:

1 . 2 7	0 0 0 2 4
	RESET

At this point, there are two options:

- 1. Cancel the cycle sequence:**
Press **RESET** to stop and reset the cycle sequence. The cycle counter will revert to the number of cycles originally programmed.
- 2. Resume the cycle sequence:**
Press either directional button to resume.

Once the sequence has been completed, the screen will revert to the number of cycles programmed originally. To begin another cycle test, press either directional button.

6 COMMUNICATION

6.1 Setup

The TSTM-DC can transmit torque and rotational travel data to a PC. The following settings are required for proper functioning of all test stand functions and data output:

Torque sensor with indicator (M5I or M7I):

- RS-232 communication
- 9600 baud rate
- Auto Output: Disabled

TSTM-DC test stand menu:

- CONTROL: CONSOLE
- STOP & PAR (stop bits and parity): 8-1n (8 data bits, one stop bit, no parity)

Connection cables:

- Torque sensor / indicator to test stand: Part no. 09-1162
- Test stand to PC (RS232): Part no. 09-1056
- Test stand to PC (USB): Part no. 09-1056 and RSU100

If not using Mark-10 data collection software, ensure that the software's communication settings match.

6.2 PC control mode

Motion control and data collection functions may be sent by an external device via user-developed applications. A list of supported ASCII commands is provided below. All commands must be lowercase.

Command	Description	Example
a	Request speed	
b	Set travel unit to revolutions	
c	Enter cycle mode	
d	Move crosshead CCW	
e	Set speed	
	RPM format: eXXX.XX Three leading zeroes and two decimal places required.	e002.85 = 2.85 RPM
	Deg/Sec format: eXXX.XX Three leading zeroes and two decimal place required.	e154.20 = 154.2 Deg/Sec
f	Set cycles. Format: fXXXX (leading zeroes required)	f0500 = 500 cycles
g	Set CCW travel limit	
	Revolutions format: g-XXXX.XX Negative sign (if applicable), four leading zeroes, and two decimal places required.	g-0010.55 = -10.55 Turns g0001.25 = 1.25 Turns
	Degrees format: g-XXXXXX.X Negative sign (if applicable), six leading zeroes, and one decimal place required.	g-000007.5 = -7.5 Deg g000010.7 = 10.7 Deg
h	Set CW travel limit	
	Revolutions format: h-XXXX.XX Negative sign (if applicable), four leading zeroes, and two decimal places required.	h-0010.55 = -10.55 Turns h0001.25 = 1.25 Turns
	Degrees format: h-XXXXXX.X Negative sign (if applicable), six leading zeroes, and one decimal place required.	h-000007.5 = -7.5 Deg h000010.7 = 10.7 Deg
i	Set travel unit to degrees	
j	Set test stand speed to maximum speed	
k	Set test stand speed to minimum speed	
l	Enter travel limit mode ¹	
m	Enter manual mode	
n	Transmit travel and force readings	
o	Set test stand speed to programmed speed	
p	Request stand status ²	
q	Request number of cycles completed	
r	Request number of cycles set	
s	Stop test stand motion	
t	Reset cycle counter to zero	
u	Move test stand CW	
v	Request CW travel limit	
w	Request CCW travel limit	
x	Request rotational travel value	
z	Reset rotational travel position to zero	

Notes:

1. If travel limit mode is disabled, torque and rotational distance limits are ignored.
2. The transmission of ASCII "p" will return the stand status. The following are the return codes and their definitions (upper case):

	Command	Description
Test Stand status	CW	Test stand moving CW
	CCW	Test stand moving CCW
	S	Test stand stopped
Operating mode	C	Cycle mode
	L	Limit mode
	M	Manual mode
Limit switch status	CWL	Test stand at CW limit
	CCWL	Test stand at CCW limit

While in PC control, if any functions are changed on the control panel, these settings will be ignored, except if Auto Return or Cycling are turned on. If so, PC control will be turned off automatically.

7 MAINTENANCE AND SERVICE

The TSTM-DC should be operated in a dry and clean area. Under these circumstances only a few periodic maintenance operations are required:

7.1 Check for loosened grips and attachments – daily

Check to ensure that the grips attached to the torque sensor and torque plate are firmly secured. Looseness could result in a potentially hazardous situation.

7.2 Check for loosened components – once per month

1. Remove the test sample from the test stand.
2. Attempt to loosen subcomponents of the test stand (ex. fasteners, brackets, etc). All components should be firmly attached. If any looseness is detected, stop using the test stand and contact Mark-10 or a distributor for instructions.

8 TROUBLESHOOTING

1. The control panel displays several error messages, as follows:

Error Message	Description
CHECK GAUGE	The torque sensor/indicator is either (1) powered off, (2) not in its operating mode (i.e. in a menu), or (3) not connected to the stand. This message appears only if overload protection is turned on and one of the above conditions is present.
GAUGE COMM ERROR	The test stand is attempting to rotate, but it cannot establish communication with the torque sensor/indicator. The communication settings in the indicator are not correct or the indicator is not in its normal operating mode.
GAUGE OVERLOAD	The programmed overload percentage of the torque sensor/indicator's full scale has been reached. Immediately reduce the torque or adjust the overload settings.

To clear any of the above errors, press **STOP**.

2. The test stand will rotate only in one direction, or not at all.

Possible causes:

1. Ensure all cables are plugged in properly, as described in **Setup and Safety** section.
2. Ensure that the torque value has not exceeded the overload limits configured in the stand.
3. Ensure that instrument's set points have been configured properly. Both set points must be enabled, regardless of test direction, with upper limit in the CCW direction, and lower limit in the CW direction. Refer to the indicator's user's guide for further instructions on configuring set points.

9 SPECIFICATIONS

Torque capacity:	TSTM-DC: 100 lbFin [11.5 Nm] TSTM-DC-1 / SP-2496 upgrade: 200 lbFin [22 Nm]*
Speed range:	TSTM-DC: 0.01 - 15 RPM [0.05 - 90°/s] TSTM-DC-2 / SP-2624 upgrade: 0.04 - 60 RPM [0.2 - 360°/s]*
Speed variation with load:	±0% (Stepper motor driven)
Speed accuracy:	±0.2% of setting
Rotational travel accuracy:	±0.7° / 0.02 rev.
Rotational travel repeatability:	0.1° / 0.01 rev.
Rotational travel resolution:	0.1° / 0.01 rev.
Maximum slider travel:	15.5" [394 mm]**
Slider travel rate:	1.047" [26.6 mm] / lever revolution
Maximum angular travel:	No limit
Manual adjustment:	12°/knob rev
Angle dial resolution:	2°
Maximum slider travel:	15.50" [394 mm]
Slider travel rate:	1.05" [26.6 mm] / lever revolution
Power:	Universal input 80-240 VAC, 50/60 Hz, 60W
Fuse type:	1.2 A, 250V, 3AG SLO BLO
Weight:	Vertical models: 35.5 lb [16.1 kg], Horizontal models: 29.5 lb [13.4 kg] Control panel: 2.7 lb [1.2 kg]
Environmental conditions:	40 - 100°F [5 - 40°C], max. 93% humidity, non-condensing

* Maximum torque decreases proportionately with speed. Examples:

- Maximum torque at 60 RPM = 25 lbFin [2.8 Nm]

- Maximum torque at 30 RPM = 50 lbFin [5.6 Nm]

**A column extension will also extend the slider travel

10 DIMENSIONS in [mm]

TSTM-DC

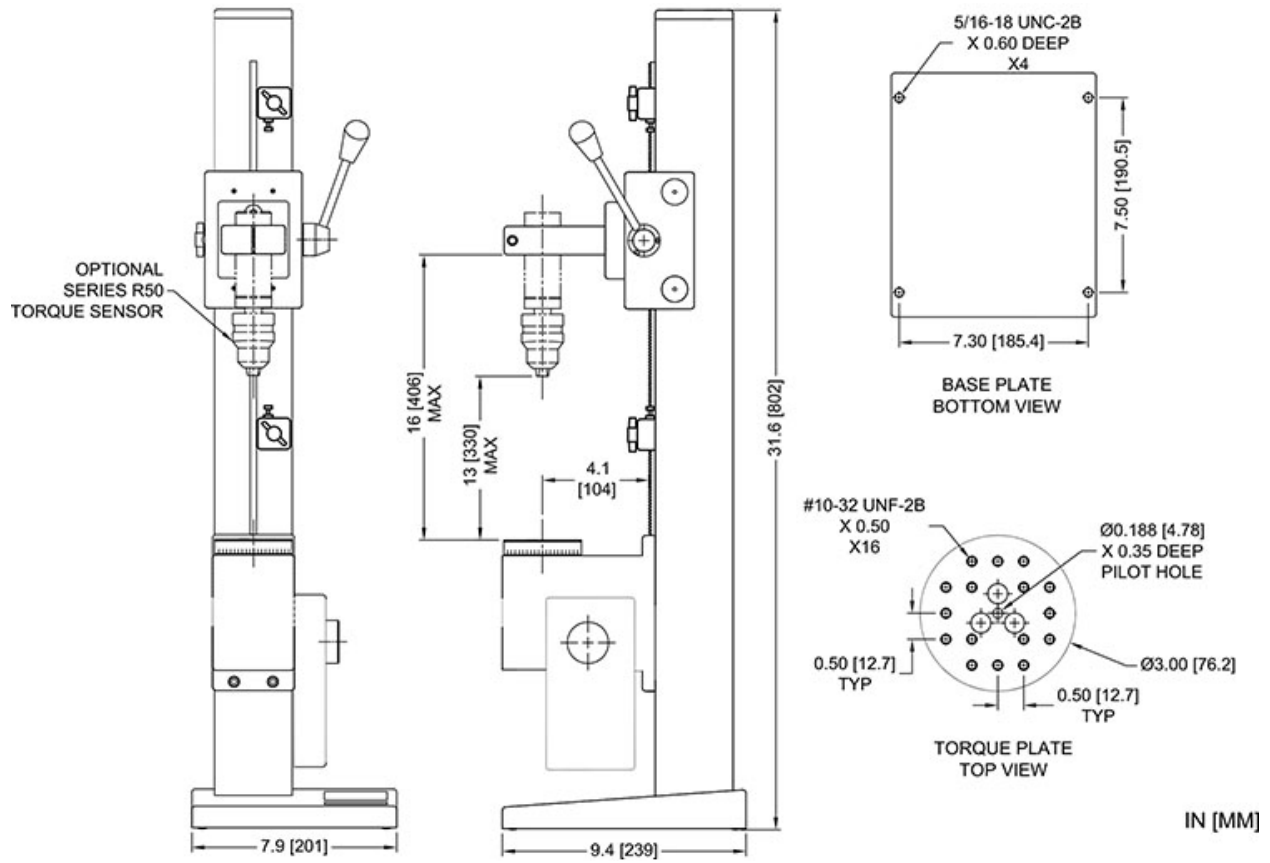

TSTMH-DC

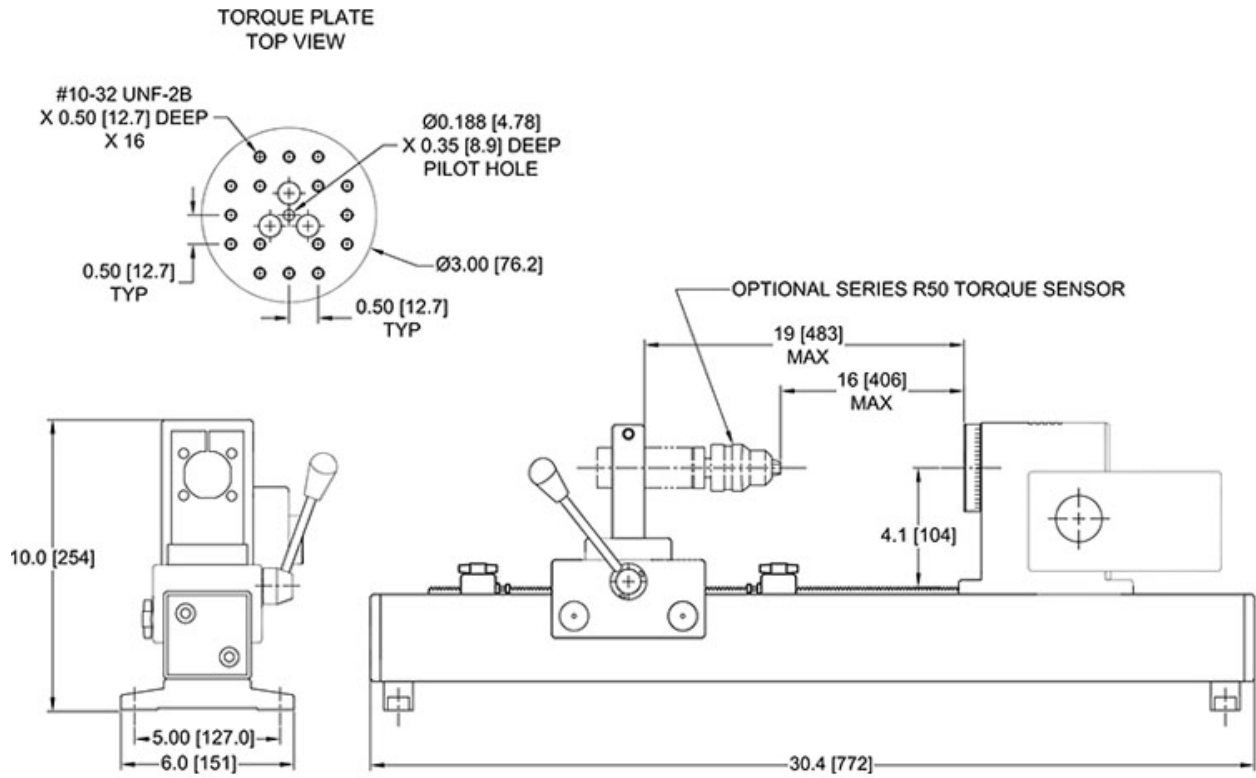

CONTROL PANEL

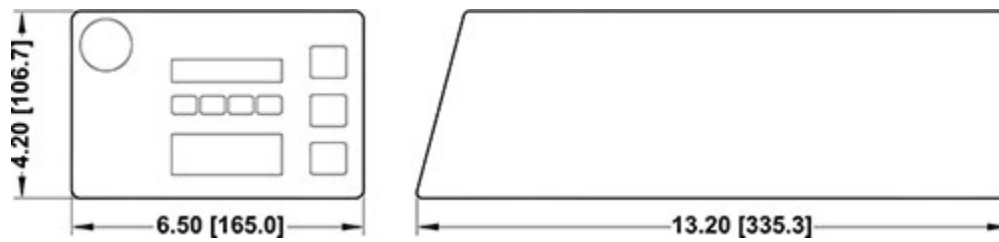

NOTES



Mark-10 Corporation has been an innovator in the force and torque measurement fields since 1979. We strive to achieve 100% customer satisfaction through excellence in product design, manufacturing and customer support. In addition to our standard line of products we can provide modifications and custom designs for OEM applications. Our engineering team is eager to satisfy any special requirements. Please contact us for further information or suggestions for improvement.



Force and torque measurement engineered better

Mark-10 Corporation

11 Dixon Avenue
Copiahue, NY 11726 USA
888-MARK-TEN
Tel: 631-842-9200
Fax: 631-842-9201
www.mark-10.com
info@mark-10.com